

2019

INFINITI TOWING GUIDE

The 2019 INFINITI Towing Guide provides information for currently available 2019 INFINITI vehicles. This publication will be amended as new vehicles are introduced.

TABLE OF CONTENTS

Introduction	1
Towing Equipment	2
What Is Right for You	3
Preparing Your Vehicle	9
Towing Safety	13
Towing Tips	16
Towing Glossary	20
Protection	22
The Total Ownership Experience	23

For important safety warnings, please read and follow your vehicle owner's manual.



INTRODUCTION

SAFETY IS PRIORITY ONE

Obviously, your first concern should be safety. Your vehicle was designed to be used primarily to carry passengers and cargo. Always remember that towing a trailer places additional loads on your vehicle's engine, drivetrain, suspension, steering, braking, and other systems. Therefore, be certain that your vehicle can meet the demands of the towing application you have in mind.

Rent or purchase only the highest-quality towing and safety equipment you can find. Reinforced tow hitches designed especially for certain INFINITI vehicles are available from your INFINITI retailer. Hitches for other INFINITI models – if INFINITI recommends towing with that vehicle – should be bought from and installed by a professional supplier of towing equipment. Carefully review all information and literature provided with any hitch you purchase for safety and proper use information. Finally, it is important to follow the towing capacity limit set for your specific vehicle and to ensure that your vehicle is in top mechanical condition, especially the tires, brakes, suspension, and engine cooling system. See your vehicle owner's manual for details.

NEVER EXCEED THE ESTABLISHED TOWING CAPACITY

Towing capacities vary from vehicle to vehicle. See the towing information in your vehicle owner's manual to confirm whether your 2018 INFINITI vehicle can be used for towing and if so it's towing capacity.

EQUIP YOUR INFINITI FOR TOWING

The frequency and type of towing dictate the manner in which you equip your vehicle. If you plan to tow often, either for recreation or work, select the engine size, transmission type, suspension, and towing capacity that are best suited to your requirements. This guide can help you select the proper equipment.

READ THIS GUIDE BEFORE YOU TOW

This guide was designed to provide an overview of safe towing practices. Here, you will find information on towing equipment, safety, proper loading and driving techniques, towing tips, and much more.

It is also a good idea to discuss your towing requirements with either your INFINITI retailer or a professional supplier of towing equipment before you equip your INFINITI vehicle for towing. Finally, there are state and local laws on towing that you should review to ensure compliance with all regulations.

▲ CAUTION: INFINITI recommends you do not use your new vehicle to tow a trailer or haul a heavy load for the first 500 miles (800 km) of use. Your engine, axle or other parts could be damaged. For the first 500 miles that you tow a trailer, do not drive over 50 mph and do not make starts at full throttle. This helps your engine and other parts of your vehicle wear in at heavier loads.

TOWING EQUIPMENT

RENTING

The first thing to keep in mind when renting any type of tow equipment, trailer, tow dolly, is to rent only from professional companies that specialize in towing and towing equipment. Specialized companies should hire professional staff that can assist you in selecting and installing the proper towing equipment for your INFINITI vehicle.

When renting, make sure you have your vehicle owner's manual on hand so that you can reference the towing capacities for your specific vehicle. Make certain that the tow equipment and components you rent do not exceed your maximum towing capacity. Make sure that any related towing equipment you rent has the proper weight class rating for your maximum intended towed load weight, and the maximum Gross Combined Weight Rating.

While you are at the rental company, ask questions. How much does the empty trailer weigh? How much weight will the trailer hold? What is the trailer's tongue load? With what type of brakes is it equipped (if any)? All of these factors have an effect on whether your INFINITI vehicle is capable of safely pulling that type of trailer, dolly, or piece of tow equipment.

Make certain that the trailer stoplights, taillights, turn signals, and brakes (if equipped) are connected and are operating correctly, and that all safety equipment is properly installed. Check the safety chains/cables, tie-downs, etc.

For safer operation, carefully inspect the condition of the trailer and towing equipment. Specifically, check to make sure the tires are not worn excessively and are properly inflated. Make sure there are not any broken welds, missing bolts, and that the hitch components are not damaged. Towing safety should be a high priority when choosing and renting towing equipment, including hitches.

▲ WARNING: NEVER RENT A CLAMP-ON-TYPE HITCH. The hitch should not be attached to or affect the operation of the impact-absorbing bumper. Use only a permanent-type hitch properly attached to the vehicle to help avoid personal injury or property damage.

PURCHASING

If you are buying a trailer, be sure that your INFINITI vehicle has the towing capacity to pull it. Refer to your vehicle owner's manual for detailed information regarding the towing capacity of your specific vehicle. Your vehicle owner's manual should ALWAYS be referenced before making any towing decisions.

Naturally, you will want to select the towing and safety equipment that adheres to federal safety regulations, as well as any regulations in any state in which you may travel.

WHAT IS RIGHT FOR

And if you plan to tow often, consider convenience. Quick-disconnect trailer light connectors and ratchet-type tie-downs, for example, make the job go faster and easier and are usually worth the extra small investment. Purchase towing items such as hitches and hitch balls only from your INFINITI retailer or a professional supplier of towing equipment.

If you are intending to use your vehicle to tow a trailer you already own, you must ensure that your loaded trailer remains well within your vehicle's towing capacity as specified in the vehicle owner's manual. In addition, you should purchase the right type, style, and class* of hitch and towing equipment to properly adapt the trailer to your vehicle.

TYPES OF EQUIPMENT

Towing requires a variety of equipment, and, depending upon the application, there can be several types or styles of each piece of equipment. Working with your INFINITI retailer or a professional supplier of towing equipment, it should be relatively simple to determine the proper type of equipment for your specific vehicle given the intended application. This section explains the most common pieces of towing equipment available.

HITCHES

Whichever type of hitch you use, it should be firmly bolted to your vehicle, and should be of the appropriate weight class for the trailer, tow dollies or towing equipment you intend to tow. In addition, keep the following in mind:

▲ WARNING- Never modify the vehicle's braking or exhaust systems or its body structure/frame when installing the hitch. Altering the brakes or structure on a vehicle could increase the likelihood of a crash.

- ◆ Installing an aftermarket hitch may affect the rear crash performance of your vehicle. Changing the crash performance of a vehicle could lead to more severe vehicle damage, personal injury or death in a crash. Be sure that the hitch does not interfere in any way with the vehicle's impact-absorbing bumper.
- ◆ Never attach a hitch or towing device to the vehicle bumper. This may affect the operation of the impact-absorbing bumper. Use only a permanent-type hitch properly attached to the vehicle to help avoid personal injury or property damage.
- ◆ Regularly check to see that all hitch-mounting bolts are securely fastened to ensure the hitch will not come loose, and remains properly attached to the vehicle to help avoid property damage, personal injury or death.

▲ CAUTION- If you have a receiver-type hitch using a ball mount; remove the ball mount when not towing, or protect it with a special cover, this will help keep it from damage, and prevent rust from forming on it.

- ◆ If you install a hitch yourself, remember that it must be securely attached to the frame or underbody, according to the manufacturer's instructions. **Never attach a hitch or towing device to the vehicle axle housing. This may damage the housing, wheel bearings, wheels, or tires.**

* Refer to your owner's manual for the equipment class information specific to your vehicle.

Hitch Types

Receiver Hitch – A receiver hitch is bolted directly to the vehicle structure for added strength and durability. INFINITI bolt-on receiver hitches are designed specifically for INFINITI vehicles and include the necessary reinforcements, with ample clearance around bumpers, frame members, etc. These hitches allow for the removal of the ball mount when not towing. Choose a proper class ball mount based on the trailer weight.

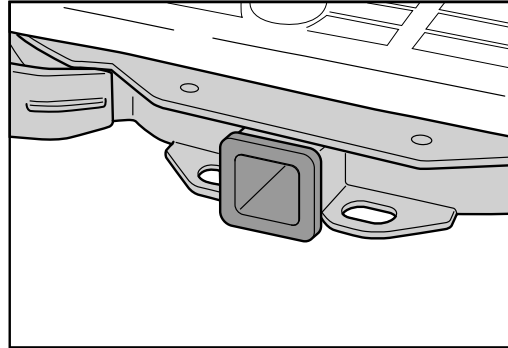

Clamp-On Bumper Hitch – This is a temporary hitch that clamps onto the bumper assembly.

⚠ WARNING: DO NOT USE this type of clamp-on bumper hitch on any INFINITI vehicle because using it may result in the trailer separating from the towing vehicle. If the trailer separates from the vehicle, it could cause a crash, resulting in property damage and personal injury, or death. Use of this type of hitch can also damage the towing vehicle.

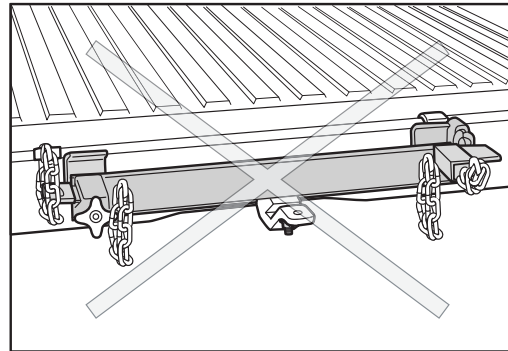

Weight-Distributing Hitch System – This type of system uses a "load-leveling" or "equalizing" hitch. The weight-distributing feature helps shift the trailer tongue weight to all the axles of the tow vehicle and the trailer axles.

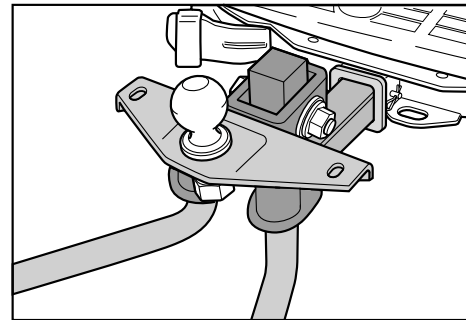

Weight -distributing hitches should be used in many towing conditions. In general, a weight-distributing hitch system is recommended and should be used if you plan to tow trailers with a maximum weight over 5,000 lbs. Refer to trailer and hitch manufacturer for detailed information on load limits. Weight distributing hitches are available in many styles and with sway control accessory options to accommodate trailers with maximum loaded weight and for different driving conditions.

NOTE – A weight-distributing hitch system may affect the operation of trailer surge brakes. If you are considering use of a weight-distributing hitch system with a surge brake-equipped trailer, check with the surge brake, hitch, or trailer manufacturer to determine if and how this can be done. Follow the instructions provided by the manufacturer for installing and using the weight-distributing hitch system.

BALL MOUNT

A ball mount (also known as a drawbar) is a bar that holds a hitch ball and is inserted into a receiver-type hitch. Ball mounts are available for a number of weight capacities (3,500 lbs., 5,000 lbs., etc.), heights, fit different hitch sizes (1 1/4", 2", etc.), and can be weight-distributing or non-weight-distributing. Choose a proper ball mount based on class, hitch size, weight rating, and the vehicle's tow capacity.

HITCH BALL

A hitch ball is bolted through a ball mount or a hitch hole in the tow vehicle's rear bumper. The coupler on the trailer tongue attaches over the hitch ball.

Like ball mounts, hitch balls are available in a number of weight capacities and sizes. Always make sure the hitch ball selected has the proper shank diameter and weight rating for the ball mount as well as the coupler on your trailer. Using a 1 7/8"

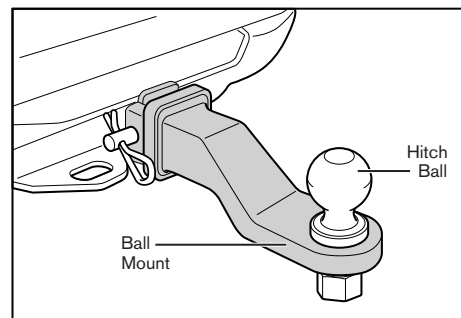

hitch ball in a 2" coupler, for example, could result in the trailer separating from the tow vehicle. The required hitch ball size is stamped on most trailer couplers.

The diameter of the hitch ball shank must be matched to the ball mount hole diameter. The shank should be no more than 1/16" smaller than the hole in the ball mount. To keep the hitch ball in top condition, a simple maintenance routine is recommended. Coating it with light grease will minimize wear of both the coupler and hitch ball. Also, by removing the hitch ball when not towing, or by protecting it with a special cover, you will help prevent rust from forming on it.

TRAILER TONGUE

The tongue is the part of the trailer that extends forward to meet the tow vehicle, and it also carries the coupler assembly. Knowledge of the trailer minimum and maximum tongue load is critical as it can have a significant effect on the handling and capacity of the tow vehicle. Refer to your vehicle owner's manual to view the maximum conventional trailer tongue load listed for your vehicle. Trailer tongue weight is the amount of downward pressure exerted onto the hitch ball. Keep the tongue load between 10-15% of the total trailer weight. **DO NOT** exceed the maximum tongue load specification. If the tongue weight is below the recommended amount, you must move some of the load forward or add weight to the front frame of the trailer.

SAFETY CHAINS/CABLES

Always use suitable safety chains/cables between the tow vehicle and the trailer. If the hitch should break or become disengaged for some reason, these chains/cables will provide an emergency connection between the vehicle and the trailer. The ultimate combined breaking strength of the two chains must be equal to the gross weight of the towed vehicle(s).

The chains/cables should be crossed under the trailer tongue and attached to the hitch or vehicle frame. Crossing the chains/cables under the tongue will help prevent the tongue from hitting the ground should the trailer become disconnected.

Be sure to leave enough slack in the chains/cables to turn corners without binding; however, note that excessive slack will allow the chains/cables to drag on the ground.

▲ WARNING- Do not use S-hooks for attaching the safety chains as they may become un-hooked while towing. If the S-hook unhooks, the emergency chains/cables will become detached, so if the tow hitch breaks or becomes disengaged, it will allow the trailer to completely break away causing property damage and possibly personal injury or death. The use of S-hooks is illegal in many states.

▲ CAUTION- To avoid damage to the bumper and chains/cables when making a sharp turn, do not attach the chains/cables too close to the coupler. Consult your trailer manufacturer for the proper location of the chain/cable attachment to the trailer.

REAR VIEW MIRRORS

▲ WARNING- In many cases, a trailer can block your rear vision when you are using only the standard INFINITI rear view and outside mirrors. Be careful when changing lanes or turning. Using only these mirrors could cause an accident as they were not designed for towing.

"Extended" mirrors specifically designed for trailer towing should be used when your rearward vision is obstructed. Before using these mirrors, make certain that they comply with state and local regulations. Telescoping Tow Mirrors are available as an accessory for certain INFINITI vehicles. Contact your INFINITI retailer for details.

SWAY CONTROL DEVICE

Sudden maneuvers, wind gusts, and buffeting caused by other vehicles can affect trailer handling. Sway control devices may help control the pivoting motion between tow vehicle and trailer and make trailer towing easier on the driver. If you choose to use one, contact a reputable trailer hitch supplier to make sure the sway control device will work with the vehicle, hitch, trailer and the trailer's brake system.

A sway control device is recommended for all towing above 2,000 lb (907 kg). Too low a percentage of tongue weight can also cause sway. Follow the instructions provided by the manufacturer for installing and using the sway control device.

BREAKAWAY SWITCH

On a trailer with electric brakes, a breakaway switch can automatically activate the trailer brake system if the trailer becomes separated from the tow vehicle. Should the trailer become detached, a breakaway switch may help prevent the trailer from wandering into another lane.

▲ WARNING- A breakaway switch relies on the power of a trailer battery, so make sure it is not discharged. Never use the breakaway switch to “park” the trailer on a grade. The battery would eventually discharge and release the brake, allowing the trailer to roll. Be sure to leave enough slack in the tether on the breakaway switch to turn corners without binding. If you do not, the electric trailer brakes will lock-up and not release. See your trailer manufacturer for proper installation of a breakaway switch that is compatible with your trailer braking system.

TRAILER LIGHTS

Trailer lights should comply with all applicable federal, state, and local regulations, and should be in proper working order at all times. If your vehicle is equipped with a towing package, a 7-pin trailer harness connector is located at the trailer hitch, under a cover on the rear bumper on some models for connecting trailer lights. For trailers that use a different style plug, contact your INFINITI retailer or a professional supplier of towing equipment for adaptors to the 7-pin trailer harness.

A trailer's taillights, stoplights, and turn signal lights must be wired into the towing vehicle's electrical system.* Most trailers operate on a four-wire system in which the stoplights and turn signal lights utilize the same wire. Most all INFINITI vehicles have separate wires for the stoplights and turn signal lights, therefore a device called a “converter” is needed.** Specifically, a “powered converter” must be used, as a converter of this type creates only minimal additional electrical demand (draw) on the vehicle lighting circuits, which helps to ensure protection for the vehicle's sensitive electronics.* Always check for correct operation of the taillights, stoplights, and turn signal lights every time you connect a trailer for towing. Never replace vehicle fuses with fuses of a higher amperage rating than the original.

*Vehicles equipped with LED taillights require that wiring be connected at a specific location. For assistance in hooking up trailer lights, contact your INFINITI retailer or a professional supplier of towing equipment.

**QX80 and QX60 vehicles are pre-wired for trailer lighting and do not require a converter.

▲ CAUTION – Improperly installed or poor quality trailer harness wiring may adversely affect your vehicle's electrical system. Use only an INFINITI approved wiring harness, or consult your retailer or a professional supplier of towing equipment for compatible equipment.

BRAKES

As with hitches, several types of braking systems are available. Most states require a separate braking system on trailers with a loaded weight above a specific amount, therefore you should check to ensure you comply with all regulations and laws. Have a professional supplier of towing equipment demonstrate proper brake function testing.

⚠ Never connect a trailer brake system directly to the vehicle brake system. Trailer brakes must be connected so that in the case of a breakaway from the towing vehicle, the trailer brakes system shall automatically apply to stop the trailer to help ensure against the possibility of a serious accident and personal injury or death.

Surge Brakes – The surge brake actuator is mounted on the trailer tongue with a hydraulic line running to each trailer wheel. Surge brakes are activated by the trailer pushing against the hitch ball when the tow vehicle is braking. Hydraulic surge brakes are common on rental trailers and some boat trailers. In this type of system, there is no hydraulic or electric connection for brake operation between the tow vehicle and the trailer.

Electric Trailer Brakes – Electric braking systems are activated by an electronic signal sent from a trailer brake controller (special brake-sensing module). If electric trailer brakes are used, INFINITI recommends the installation of a trailer brake controller. If you use an all-electronic actuation system it will not be necessary to tap into the tow vehicle's hydraulic system. For adjustment specifications refer to the brake controller manual for the controller being used.

For your convenience, QX80 and QX60 vehicles are pre-wired to accommodate most popular electric trailer brake controllers. A wiring harness* is either included with your vehicle or available from your INFINITI retailer. This harness provides electric trailer brake controller input and output connections to the vehicle wiring. Contact an INFINITI retailer or a professional supplier of towing equipment for information on trailers equipped with electric brakes and for Genuine INFINITI jumper harness availability for your specific vehicle.

⚠ **CAUTION**- Improper or poor quality trailer harness wiring may affect your vehicle's electrical system. Use only an INFINITI approved wiring harness, or consult your retailer or professional supplier of towing equipment for compatible equipment and to have it installed.

GENUINE INFINITI PARTS AND ACCESSORIES

Whether you will be towing occasionally or on a regular basis, INFINITI offers a full range of Genuine INFINITI Parts and Accessories to help you tow with confidence. Every accessory is thoroughly tested and inspected for fit and workmanship. Therefore, you can be certain that every item is designed to be compatible with the standard features of your vehicle and designed to assist you with your towing needs.

*Contact your INFINITI retailer for more information on accessories or towing-related parts for your INFINITI vehicle.

PREPARING YOUR VEHICLE

BREAK-IN AND MAINTENANCE SCHEDULE

▲ CAUTION- INFINITI recommends that you allow a sufficient “break-in” of both the engine and drivetrain before towing with your new INFINITI vehicle.

DO NOT tow a trailer or haul a heavy load for the first 500 miles. For the first 500 miles that you tow a trailer, **do not** drive over 50 mph and **do not** make starts at full throttle. Following these recommendations helps your engine and other parts of your vehicle wear in at heavier loads.

Keep in mind, too, that towing places higher demands and added loads on vehicle components, so more frequent maintenance is called for. Your INFINITI Service & Maintenance Guide provides the accelerated maintenance schedule for towing purposes. Engine oil, filter, transmission oil, and possibly other fluids should be changed more frequently when towing.

TIRE PRESSURE

When towing a trailer, increase the tow vehicle tire pressures to the recommended cold specifications. You will find these figures in the vehicle owner’s manual and on the tire pressure chart located within the vehicle. Trailer tire condition, size, load rating, and inflation pressure must be in accordance with the trailer and tire manufacturer’s specifications.

MEASURING VEHICLE WEIGHT

The key to safer, efficient towing has to do with weight. Your vehicle — SUV, or crossover vehicle — is capable of carrying and towing only a certain amount of weight. You must compare your vehicle’s tow weight ratings with the combined weight of the vehicle, trailer, and their contents. This will help ensure that the total weight does not exceed any of your vehicle’s tow weight ratings. There are four weights to consider when towing:

- ◆ Gross Vehicle Weight- curb weight of vehicle plus the combined weight of passengers and cargo
- ◆ Gross Axle Weight (Front and Rear)- maximum weight (load limit) that can be specified for front or rear axle
- ◆ Gross Combined Weight- maximum total weight of vehicle, passengers, cargo, and trailer
- ◆ Trailer Tongue Load- the weight exerted at the vehicle-trailer coupling point

These ratings are based upon normal highway driving and may be reduced if operating in reduced-traction situations (for example, slippery boat ramps).

▲ WARNING- Attempting to tow loads greater than the GVWR, GAWR, GCWR, and the trailer tongue load specified could adversely affect vehicle handling, braking, and performance. If you do, parts of your vehicle can break, and tire damage could occur as a result of overloading which may not be covered by your vehicle warranty. Overloading can also result in loss of control of your vehicle and which could cause a serious accident, personal injury or death.

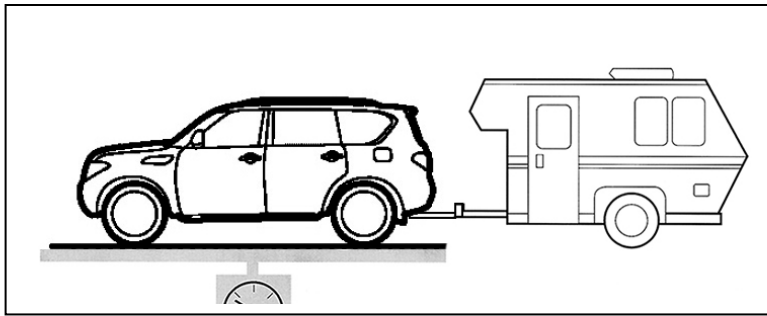

GROSS VEHICLE WEIGHT (GVW)

The Gross Vehicle Weight (GVW) is the actual weight of the fully loaded vehicle or trailer, including passengers, cargo, and fuel, hitch, trailer tongue weight, and any optional equipment.

The best way to determine the GVW is by having the vehicle — loaded and ready to tow — weighed at a public scale. That figure must include the combined weight of all passengers and cargo that are normally in the vehicle when towing a trailer.

The GVW of the towing vehicle must not exceed the Gross Vehicle Weight Rating (GVWR) shown on the Federal Motor Vehicle Safety Standard (F.M.V.S.S./C.M.V.S.S.) certification label located in the driver's-side door area. Weigh your vehicle on a platform type scale with all of the passengers and cargo that are normally in the vehicle when towing a trailer. Subtract the actual vehicle weight from the GVWR. The remaining amount is the available maximum tongue/king pin load.

To avoid overloading the vehicle, be sure to include the trailer tongue weight as a part of the cargo when determining how much weight can be safely carried inside the vehicle. The weight of any roof rack cargo should also be included.

**F.M.V.S.S.
Certification Label**

MFD BY NISSAN MOTOR CO., LTD

DATE		
GVWR		
GAWR FR.		
WITH		TIRES
	RIMS AT	PSI
COLD SINGLE		
GAWR RR.		
WITH		TIRES
	RIMS AT	PSI
COLD SINGLE		

THIS VEHICLE CONFORMS TO ALL APPLICABLE FEDERAL MOTOR VEHICLE SAFETY STANDARDS IN EFFECT ON THE DATE OF MANUFACTURE SHOWN ABOVE. SEE OWNERS MANUAL FOR ADDITIONAL INFORMATION.

TYPE: TRUCK		
MODEL:		3B000
COLOR	TRIM	TRANS
AXLE	ENGINE	

2019 INFINITI Towing Guide

10

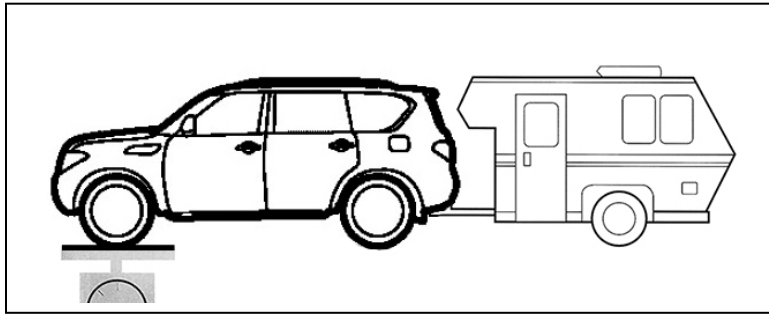

GROSS AXLE WEIGHT (GAW)

The Gross Axle Weight (GAW) is the maximum weight placed on a single axle (front and rear) that it is designed to safely carry.

To determine the GAW, load the vehicle as you would for towing and attach the loaded trailer. At a public scale, with the loaded trailer attached, place only the tow vehicle front wheels on the scale to determine the actual **front axle** GAW. To obtain the **rear axle** GAW, place all four tow vehicle wheels on the scale. From that figure, subtract the front GAW and you will have the rear GAW amount. The cargo in the trailer and the vehicle may have to be moved, or removed to meet the specified rating.

The GAW you come up with must not exceed the Gross Axle Weight Rating (GAWR) for your vehicle. On INFINITI vehicles, the GAWR for both axles is listed on the F.M.V.S.S. certification label.

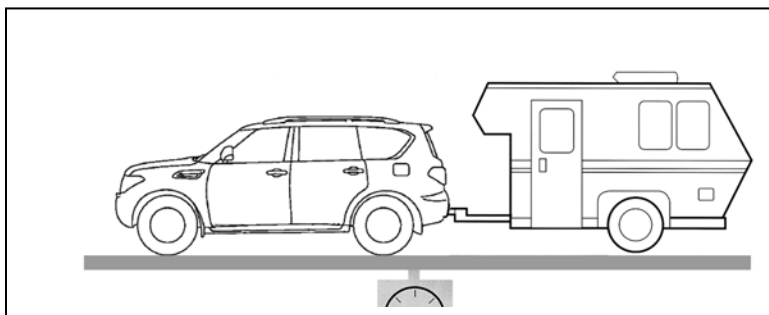

GROSS COMBINED WEIGHT (GCW)

The Gross Combined Weight (GCW) is the total weight of the tow vehicle with all passengers, cargo, and fuel, **plus** the total weight of the trailer and all its cargo.

To determine the GCW, simply weigh your vehicle when fully loaded and ready to tow, and add in the weight of the loaded trailer.

The GCW you come up with must not exceed the Gross Combined Weight Rating (GCWR) for your vehicle. Refer to your vehicle owner's manual to view the maximum GCWR specification listed for your vehicle.

TRAILER TONGUE LOAD

Trailer tongue load is the amount of trailer's weight pressing down on the tow vehicle hitch ball. To measure trailer tongue load, place the tongue of the trailer on a scale when the trailer is not attached to the vehicle. A separate vehicle jack — not the trailer jack — should be used, as the location of the trailer jack is

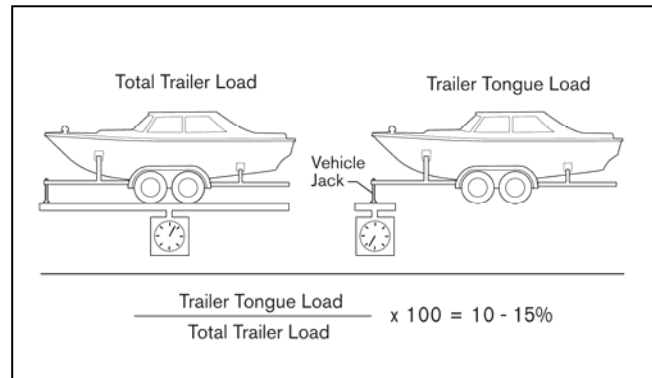

rearward of the trailer tongue and will not give you an accurate measurement of the true tongue load. Make sure the vehicle jack is placed directly under the trailer tongue coupler, and the tongue is set at the height/level of the tow vehicle hitch.

For proper handling, you must keep the trailer tongue load between 10-15% of the actual trailer weight, within the limits of the maximum trailer tongue load allowable. For example, to determine the proper trailer tongue load for a 1,500-lb. trailer, multiply the weight of 1,500 lbs. by 10% to arrive at a figure of 150 lbs. Some trailer types may require different trailer tongue loads for safe towing. Always follow the trailer manufacturer's recommendations for proper trailer set-up and trailer tongue load. Keep the trailer tongue load within the maximum trailer tongue load allowable. Additionally, make sure the vehicle has the payload capacity available for the trailer tongue load. If the tongue load becomes excessive, rearrange cargo to allow for proper tongue load. Refer to your vehicle owner's manual to view the maximum trailer tongue load listed for your vehicle.

HITCH & TRAILER HEIGHT

It is important that your trailer floor and tongue ride as level as possible. This will help prevent over-angling, bottoming-out, and improper tongue load and load transfer. Therefore, the hitch or trailer tongue must be adjusted during the initial vehicle/trailer fit-up to ensure a level ride. Ball mounts and weight distribution hitches are available

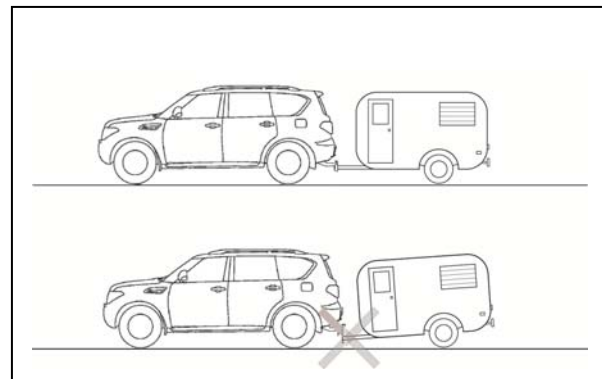

TOWING SAFETY

in different configurations to adjust the tongue load and load transfer and hitch ball height. On some tandem axle trailers an incorrect hitch height can result in uneven trailer axle loading.

▲ WARNING- Towing can significantly alter the handling and performance characteristics of your vehicle. Moreover, it puts increased strain on the engine and drivetrain. Therefore, it is always a good idea to approach towing from the standpoint of safety — whether you are purchasing equipment or actually pulling the trailer.

▲ WARNING- Always make sure your vehicle's towing capacity is adequate for the trailer you intend to tow. Be certain that you have all of the proper equipment needed for safe towing, such as safety chains/cables, electric trailer brakes, electric trailer brake controller, breakaway switch, and extended rear view mirrors. Make certain your equipment conforms to all federal, state or local regulations to help ensure against the possibility of a serious accident and personal injury or death.

You should follow a more frequent maintenance schedule and check fluid levels, pressures, tire condition, etc., more often when on the road. See your vehicle owner's manual for details.

LOADING YOUR TRAILER

▲ WARNING- Taking the time to load and balance your trailer properly will improve overall handling and minimize the strain on your tow vehicle. Incorrectly loaded trailers tend to sway or swing from side to side, upsetting vehicle handling which could result in a serious accident, personal injury or death. Careful loading and balancing, and a weight distribution hitch and sway-control device can help eliminate these problems.

As mentioned earlier, conventional trailer tongue load must fall between 10-15% of the total trailer weight, or within the limits of the maximum trailer tongue load specified by the trailer manufacturer.

▲ WARNING- Excessive trailer tongue load can actually push down the tow vehicle in back, lifting the front wheels to a point where traction, steering response, and braking may be severely reduced. which could result in an accident, personal injury or death. Too little trailer tongue load or negative load can lift the trailer tongue upwards on the trailer ball causing instability, which may lead to swaying, "tail wagging," or jackknifing which could result in an accident, personal injury or death.

With this in mind, proper loading is extremely important. When loading a trailer, 60% of the total cargo weight should be positioned in the front portion of the trailer and 40% in the back. Then the load should be adjusted until the proper tongue load ratio is achieved.

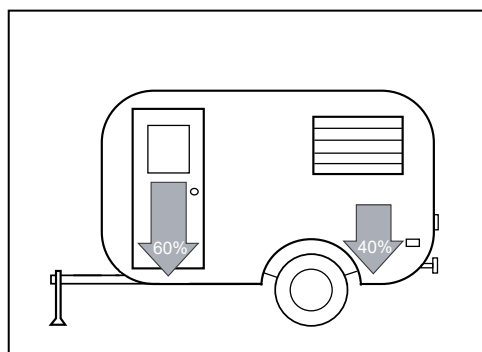

▲ WARNING-The trailer load should be balanced equally from side-to-side. Unequal side-to-side loading can negatively affect handling and braking. Once in place, all cargo should be firmly secured to prevent shifting. If the load should shift abruptly during braking or cornering, it could adversely affect the handling of your vehicle and cause a very unsafe situation and may lead to an accident or personal injury. • **DO NOT** carry flammable materials, such as gasoline, in your trailer. In the event of an accident, an explosion or fire could occur.

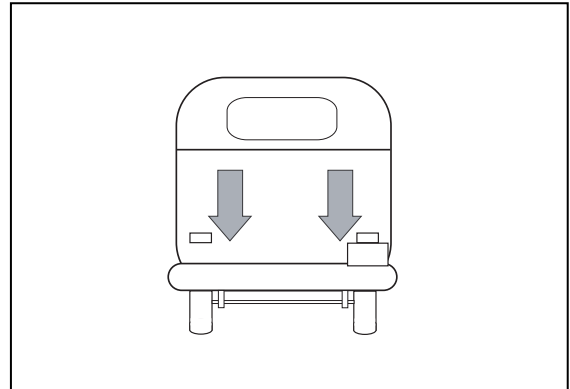

PROVIDING FOR VEHICLE/TRAILER STABILITY

▲ WARNING- Improper loading, excessive or insufficient trailer tongue load, overloading, excessive trailer weight, poorly designed trailer suspensions, crosswinds, and poor maintenance are all things that can affect the stability of your vehicle and trailer combination. Vehicle instability may result in loss of vehicle control and cause an accident, personal injury or death.

If swaying occurs, gradually reduce speed, and apply only the trailer brakes to help reduce sway. Steady the steering wheel and gradually pull over and stop to check the cargo load for proper balance and distribution to ensure proper trailer tongue load. In addition, check the condition of the suspension and shocks, as well as the tires, tire pressures, and wheel bearings on both the tow vehicle and trailer.

If the swaying continues and your trailer is suitably balanced and within the towing capacity limits of your vehicle, discontinue towing and consult your INFINITI retailer or trailer manufacturer to determine the problem.

VEHICLE SPEED

Please note that some states have specific regulations and speed limits for vehicles that are towing trailers. Remember to reduce your speed in unsafe or less-than-ideal road conditions or weather. When towing a trailer, braking distances increase while handling agility decreases. Always leave yourself an extra margin of distance to respond to emergencies.

TOWING TIPS/CAUTIONS &

PASSENGERS

▲ WARNING- Never allow passengers to ride inside a trailer while it is being towed.

Not only is this unlawful in most areas, passengers could be seriously injured during sudden trailer movement or in an accident. In addition, trailers may allow fumes from the tow vehicle to leak inside. This could result in carbon monoxide poisoning from the engine exhaust.

VEHICLE MODIFICATIONS

▲ WARNING - DO NOT modify your vehicle beyond those required for proper hitch installation, wiring hook-up, or adding extended mirrors on any INFINITI vehicle being used for towing purposes. Changes to the drivetrain, suspension, exhaust systems, electrical, frame structure/unibody, or other vehicle components are not necessary for towing within the limits described in this guide. These changes may diminish the reliability and longevity of your vehicle, void warranty coverage or possible result in loss of vehicle control and cause an accident, personal injury or death.

TOOL KIT

When towing, bring tools including flares, a flashlight, emergency reflectors, jumper cables, extra fuses, extra radiator coolant, oil, and easily replaced spare parts such as taillight bulbs. You should also carry spare tires for your tow vehicle and trailer, as well as a jack suitable for use on the trailer. Choose a jack that can raise and lower the trailer so that you can connect the coupler to and disconnect it from the ball of your hitch. Choose one with a weight capacity that matches or surpasses your trailer tongue weight.

▲ WARNING- Be aware that your automotive jack is designed for lifting only your vehicle during a tire change. Using an automobile jack to lift a trailer-bearing load may be unstable possibly causing it to fall off the jack stand which may result in property damage or serious injury or death.

BEFORE STARTING OUT

Before starting out on a trip, make one last inspection of the tow vehicle and the trailer. Are the tire pressures correct? Are the safety chains/cables securely in place? Is the cargo tied down securely? Do all the lights work? Is the coupler properly attached over the hitch ball and secured using a locking pin? Is the breakaway switch hooked up and functioning properly? Are vehicle and electric trailer brakes working properly?

Make a checklist of key items to inspect. When towing, vehicle engine oil, transmission oil, and coolant should always be checked before starting out. Finding a potential problem while in your driveway is better than discovering it miles from home. If you have never towed a trailer before, be aware that it does take getting used to.

To begin with, towing noticeably affects your vehicle's performance:

- ◆ It will not accelerate as quickly — an important point to keep in mind when merging onto a highway.
- ◆ It will not stop as quickly. Leave more room than usual between you and the traffic ahead, and brake sooner when coming to a stop.
- ◆ Abrupt maneuvering can unbalance the load and reduce the handling and stability of your tow vehicle. Plan ahead and make lane changes and turns smoothly.

If possible, before you actually hit the open road, practice towing in a large uncrowded area such as a safe, open place with minimal traffic. Become especially familiar with backing up a trailer — the maneuver many people find most difficult.

BRAKE SOONER

The combination of your tow vehicle and trailer obviously requires a greater distance to stop. A good rule of thumb to remember is that for each 10 mph of speed, allow yourself one tow vehicle and trailer length of distance between the front of your vehicle and the vehicle ahead. When braking, use firm but gradual pressure on the pedal rather than panic braking.

▲ WARNING- Applying the brakes abruptly or with too much force can cause the trailer to skid or jackknife at its point of attachment with the vehicle. This, in turn, can throw the tow vehicle out of control. If equipped with an electric trailer brake controller, follow the recommended operational instructions.

CORNER MORE SLOWLY

Know your vehicle and trailer capabilities.

▲ WARNING- Entering a sharp corner too quickly or abruptly can “crack the whip,” whereby the trailer can actually pull the tow vehicle off the road resulting in property damage, a serious accident, personal injury, or death.

Therefore, when approaching a relatively sharp corner, begin braking sooner than you would when not towing. Do your braking in a straight line prior to the corner, and turn smoothly into it. In addition, remember to make a wider turn than normal to ensure that the trailer safely clears the inside of the turn.

BACK UP WITH CAUTION

Backing up with a trailer is a difficult maneuver. Steer with one hand at the bottom of the steering wheel. To turn the trailer to the left, first move the steering wheel to the left. To turn the trailer to the right, move the wheel to the right. All movements of the wheel should be done in small increments. Of course, backing up should be done only at very slow speeds. For large trailers that obstruct your rearward vision, have someone outside the vehicle act as a “spotter” to guide you along.

▲ WARNING- Do not use or rely upon the Back-up Collision Intervention system (BCI) when towing a trailer. The BCI system cannot function properly when objects are obstructing the radar sensor beams.

PARK SMART

A tow vehicle and trailer can be an unwieldy combination in a small area, so always try to park where you will have a relatively easy time maneuvering. Once parked, always block the wheels on both the tow vehicle and the trailer.

Parking on a slope is not recommended. If, however, you must park on a slope and your vehicle is equipped with an automatic transmission, there are some precautions you should take:

- ◆ Turn the wheels of the tow vehicle towards the side of the road away from the center of the road, and apply the parking brake and only then move the gear lever into PARK.
- ◆ Next, block/chock the wheels once the tow vehicle and trailer are in position and are being held by the vehicle's brake.

▲ CAUTION- If you move the lever into PARK before blocking the wheels and applying the parking brake, it may be difficult to later shift out of PARK. Transmission damage may also occur.

PASS CAREFULLY

As mentioned in the introduction to this section, because of the added weight of the trailer, acceleration capability is reduced and you will require a longer distance to pass another vehicle. Be certain you have sufficient time and space to pass safely.

▲ WARNING- Never attempt to pass on hills or when going around curves. Doing so could cause a loss of vehicle control and result in accident, property damage or personal injury. Because the trailer does not follow the exact path as the tow vehicle on turns, safely passing and cornering while towing takes considerably more distance and turning space than normal. Be certain you have sufficient time and space to pass safely, remember, the length of the trailer must also pass the other vehicle before you can safely change lanes.

HILLS – UPGRADES

If your vehicle is equipped with an automatic transmission, it is designed to select automatically the correct gear for the best towing comfort and performance as the incline increases. To maintain speed or avoid up and down shifts, manually shift to a lower gear as needed. The added weight of a trailer places an increased load on the engine and cooling system, so monitor your coolant temperature gauge and automatic transmission fluid temperature gauge (if equipped) carefully. At the first sign of overheating, pull to the side of the road. See IF YOUR ENGINE OVERHEATS later in this section for more information.

HILLS – DOWNGRADES

▲ WARNING- While going downhill, the weight of the trailer pushing on the tow vehicle may decrease overall stability, and may deteriorate overall handling characteristics. The vehicle may handle unpredictably which could cause a loss of vehicle control resulting in an accident, property damage, serious injury or death. Therefore, to maintain adequate control, reduce your speed and shift to a lower gear and apply the braking in short bursts. If your vehicle is equipped with Tow Mode, see your vehicle owner's manual for information about the use of this function.

▲ WARNING- Avoid long or repeated use of the brakes when descending a hill, as this reduces their effectiveness and could cause overheating which could result in damage to your brake components or unable to slow to a safe speed. Shifting to a lower gear instead provides "engine braking" and reduces the need to brake as frequently.

HIGH-ALTITUDE PERFORMANCE

An engine will lose about 4% of its performance for every 1,000 feet above sea level that you travel. If you will be towing in high altitudes, it is a good idea to allow more time than usual due to the engine's reduced performance.

INTELLIGENT CRUISE CONTROL

▲ WARNING- In order to maintain a safe distance to the vehicle ahead to avoid the possibility of accidents, property damage, serious injury or death. INFINITI recommends not to use the Intelligent Cruise control (ICC) system while towing a trailer or other vehicle. In certain road conditions when your vehicle is towing, the ICC sensor may not detect a vehicle ahead. If the ICC sensor cannot detect the reflector on the vehicle ahead, the ICC system may not maintain the selected distance which could cause an accident, property damage, or death.

BLIND SPOT INTERVENTION

▲ WARNING- Do not use or rely upon the Blind Spot Intervention system (BSI) when towing a trailer. The BSI system cannot function properly when objects are obstructing the radar sensors which could cause an accident, property damage, or death.

TOW MODE (IF SO EQUIPPED)

Tow Mode is recommended when towing a heavy trailer or hauling a heavy load, in stop-and-go traffic, rolling terrain, or a busy parking lot. Driving the vehicle in Tow Mode may affect fuel economy and transmission/engine driving characteristics. See your vehicle owner's manual for additional information about Tow Mode.

IF YOUR ENGINE OVERHEATS

A moderate increase in engine operating temperature is normal when towing a trailer. If, however, the coolant temperature gauge reading is abnormally high, or if you are experiencing a significant loss of power, or if you hear unusual engine noises,* the engine may be overheating and you should immediately take the following steps:

1. Pull your vehicle safely over to the side of the road, out of traffic. Apply the parking brake and move the gearshift lever to NEUTRAL (manual) or PARK (automatic). **DO NOT STOP THE ENGINE.**
2. Turn off the air conditioning and, after opening all the windows, turn the heater on to maximum hot and the fan to its highest speed, and exit the vehicle. The heater core in your vehicle is just like a miniature engine radiator and will provide an extra cooling surface to help reduce engine temperature.

*See your vehicle owner's manual for additional indications that your vehicle may be overheating.

3. If the temperature does not drop or continues to increase, stop the engine immediately.
4. Being cautious of traffic, step out of the vehicle and, from a safe distance, look for steam underneath the engine. If you see steam or leaking coolant, stand clear to avoid being burned and shut off your engine immediately and allow it to cool. If there is no steam, open the hood.

▲ WARNING -Never remove the radiator cap when the radiator is hot. If the cap is removed under these conditions, pressurized hot water/coolant may spurt out, possibly causing serious injury.

5. As soon as the engine has cooled to its normal operating temperature, visually inspect the drive belts for damage or looseness. A loose belt reduces water pump efficiency.

▲ WARNING- Be careful to keep your hands, hair, jewelry, and clothing clear of the running drive belt and other moving parts when inspecting the engine and radiator. Also check to see if the cooling fan is running, and inspect the water pump, radiator, and radiator hoses for leaks. Keep in mind, too, that if your vehicle is equipped with an electric fan motor, it may start without warning any time the coolant temperature is high. If you find leaking coolant, a loose or missing drive belt, or an inoperable fan, turn off the engine immediately.

6. If no leaks are apparent and all other components appear to be operating properly with the engine cooled to its normal operating temperature; check the coolant level in the reservoir tank with the engine running. Add coolant to the reservoir tank if needed. At this point, if repairs are required, go to the nearest INFINITI retailer. See the IN CASE OF EMERGENCY section of your vehicle owner's manual for additional information on overheating.

NOTE – All INFINITI vehicles have an engine protection mode which helps reduce the chance of engine damage if the engine coolant reaches a specified temperature.

NOTES

- 1 Maximum Trailer Weight values are calculated assuming a base vehicle with driver and any options required, to achieve the rating. Additional passengers, cargo and/or optional equipment will add weight to the vehicle and reduce your vehicle's maximum towing capacity and trailer tongue load.
- 2 In general, a weight-distributing hitch system (Class IV) should be used when towing over 5,000 lbs.
- 3 Most states require a separate braking system on trailers with a loaded weight above a specific amount. Check local ordinances. 7-pin connector trailer wire harnesses are required for use with trailer brakes (available separately).

Passenger Vehicles – INFINITI **cautions** that you **do not** tow a trailer with Q50, Q60, Q70, or Q70 (HEV) vehicles.

Cross-Over Vehicles – INFINITI **cautions** that you **do not** tow a trailer QX30, QX50, or the QX70 2WD vehicles.

Other Recommendations and Information – Towing performance and speed are affected by vehicle payload, tow weight, road grades, and weather conditions, including high temperatures. See your vehicle owner's manual for details.

TOWING GLOSSARY

BALL MOUNT *A bar that holds the hitch ball and is inserted into the hitch receiver. Also commonly called a drawbar.*

BREAKAWAY SWITCH	<i>A safety device using a trailer battery that automatically applies the trailer's brakes if it should accidentally become separated from the tow vehicle. A breakaway switch may be used with both electric or surge trailer brake systems.</i>
BUMPER HITCH	<i>A reinforced bumper designed to accommodate a hitch ball.</i>
ELECTRIC TRAILER BRAKES	<i>When the brakes on a tow vehicle are applied, an electric current is sent to an actuator which applies the trailer's brakes.</i>
ELECTRIC TRAILER BRAKE CONTROLLER	<i>A device that controls the electric trailer brakes.</i>
GROSS AXLE WEIGHT RATING (GAWR)	<i>The maximum amount of weight each vehicle axle (front and rear) is designed to safely carry.</i>
GROSS COMBINED WEIGHT RATING (GCWR)	<i>The maximum allowable combined weight of the vehicle and trailer, including passengers and all cargo.</i>
GROSS VEHICLE WEIGHT RATING (GVWR)	<i>The maximum allowable weight of the vehicle, including passengers, cargo, fuel, hitch, trailer tongue load, and any optional equipment.</i>
HITCH BALL	<i>A ball that connects the trailer to the tow vehicle hitch that provides the means by which the trailer pivots during cornering. Available in a number of sizes and weight capacities, it must correspond to the trailer coupler size, and have a sufficient capacity rating for the trailer being pulled.</i>
RECEIVER HITCH	<i>A frame- or structure-mounted hitch with a receiver that allows removal of the ball mount.</i>
SAFETY CHAINS/CABLES	<i>Provides an emergency connection between the tow vehicle and the trailer, should the trailer become disengaged for any reason.</i>
SURGE BRAKES	<i>Hydraulic-type braking system activated by inertia. As the tow vehicle begins to brake, the trailer pushes against the hitch ball, consequently activating the trailer brakes.</i>
TRAILER TONGUE/COUPLER	<i>The part of the trailer that extends forward to meet the tow vehicle, and carries the coupler assembly.</i>
TRAILER TONGUE LOAD	<i>The amount of trailer weight pressing down on the hitch.</i>
WEIGHT-DISTRIBUTING HITCH SYSTEM	<i>Type of hitch system that helps shift the trailer tongue weight to all trailer tires and the tow vehicle front tires. Strongly recommended when towing trailers with a Maximum Trailer Weight greater than 5,000 lbs.</i>
WIRING HARNESS	<i>Provides an electrical connection linking the tow vehicle's electrical system to the trailer's system.</i>

PROTECTION

At INFINITI, we back everything we build. So we are proud that every INFINITI is protected by some of the best New Vehicle Limited Warranties, including 4-year/60,000-mile (whichever comes first) Basic coverage. All 2018 models also feature 72 month/70,000-mile (whichever comes first) Powertrain coverage.*

For additional peace of mind, the Elite INFINITI Extended Protection Plan provides you with quality long-term mechanical protection for 8 years/120,000 miles (measured from in service date and zero miles, whichever comes first)** — long past your vehicle's Basic and Powertrain Limited Warranty. With the extra coverage, if a covered component fails during the term of the plan, INFINITI pays... not you.** Plus, the Elite INFINITI Extended Protection Plan includes extensive Roadside Assistance benefits and car rental coverage.

All of this makes the Elite INFINITI Extended Protection Plan a truly comprehensive package, offering INFINITI owners exceptional value and peace of mind. Coverage is available throughout the United States. Repair work will be done at authorized INFINITI retailers by INFINITI-trained technicians utilizing Genuine INFINITI Parts.

For more information about the Elite INFINITI Extended Protection Plan, contact your participating INFINITI retailer or call 1-800-662-6200.

The quality of Genuine INFINITI Parts and Accessories is backed by the integrity of a Genuine INFINITI Replacement Parts and Accessories Limited Warranty. If purchased within the Basic coverage period of 4 years/60,000 miles (whichever comes first), Genuine INFINITI Parts and Accessories are covered by the remaining period of the warranty. If the remaining period is less than 12 months/12,000 miles (or if the vehicle warranty has expired), then Genuine INFINITI Parts and Accessories except for replacement audio components are covered by their own 12-month/12,000-mile from the date of installation or purchase (whichever comes first). See your INFINITI Warranty Information Booklet or ask your INFINITI retailer for specific details.

CONCERN FOR YOUR SAFETY

INFINITI urges you to always use your seat belt whenever you drive. And please make sure all passengers are buckled up. Keep in mind that air bags are a supplemental restraint system and must always be used in conjunction with a seat belt.

In addition, a rear-facing child restraint must never be used in the front passenger seat if the vehicle is equipped with a front passenger air bag. Children 12 and under should ride in the rear seat properly secured in child restraints, booster seats, or seat belts, according to their size. Please see your vehicle owner's manual for more details.

*For complete warranty details, refer to the INFINITI Warranty Information Booklet or see your nearest INFINITI retailer.

**A nominal deductible may apply. For details please refer to the Elite INFINITI Extended Protection Plan Service Agreement or contact your INFINITI retailer.

THE TOTAL OWNERSHIP EXPERIENCE®

By far the most important benefit of INFINITI luxury is the Total Ownership Experience.® Years before we ever built our first luxury car, we built this belief: Luxury is much more than a collection of features on an automobile. It is a way of doing business based upon building a lasting relationship. From the very moment you arrive at an INFINITI retailer, we strive to exceed your expectations at every turn with our line of products and our people. You will notice our commitment to your satisfaction in everything we do, from the way we build our vehicles to the way we support them for years to come. As an INFINITI driver you will enjoy a host of useful services like 24-hour Roadside Assistance,* a Complimentary INFINITI Service Loan Car** and Trip Interruption Benefits.* Your ownership experience will be a complete one, extending from our showroom to our Web site and beyond.

ROADSIDE ASSISTANCE PROGRAM

4-year/unlimited-mileage* includes: Trip Interruption Benefits, 24-hour toll-free customer assistance number, battery boost, lock-outs, flat tires, out-of-gas, accident towing.

SERVICE LOAN CAR PROGRAM

When you make an appointment and drop off your INFINITI vehicle for warranty repair maintenance at participating retailers, a complimentary INFINITI Service Loan Car** will be waiting. And before your INFINITI is returned to you, it will be hand-washed and running smoothly.

COMMITMENT

To a superior product representing excellent value, presented in a unique environment. To honor our guests and treat them with respect during the buying process. To give our customers outstanding service throughout their ownership, so that they may enjoy an ongoing relationship with knowledgeable people. To be completely committed to ensuring total satisfaction for our customers.

OWNERSHIP ONLINE

Our goal is to provide owners with a premium quality vehicle and an outstanding ownership experience that does not end when you drive away from the showroom. To that end, we have created the "Ownership" section of the www.INFINITIUSA.com Web site, which further reflects our commitment to serving INFINITI owners' needs. There you can find easily accessible maintenance schedules, warranty information, and articles exclusively available to INFINITI owners.

*Roadside Assistance/Trip Interruption available during the first four years after initial new vehicle delivery.

**Subject to availability. Available only during the 4-year/60,000-mile Basic coverage. The customer must be 21 years of age or older with a valid U.S. driver's license. The customer must provide proof of primary insurance. Restrictions may apply.

All rights reserved. All illustrations, and specifications in this document are based on the latest product information available at the time of publication. Some vehicles are shown with optional equipment. See the actual vehicle for complete accuracy. Availability and delivery times for particular models and equipment may vary. INFINITI Division of Nissan North America, Inc. reserves the right to make changes at any time, without prior notice, in prices, colors, materials, equipment, specifications, and models, and to discontinue models or equipment. Specifications, options, and accessories may differ in Hawaii, U.S. territories, and other countries. For information on availability, options or accessories, contact your INFINITI retailer.

INFINITI, the INFINITI Brand Symbol, the "EMPOWER THE DRIVE" slogan and INFINITI Model Name(s) are Nissan trademarks.

Publication: April 2018
©2018 INFINITI Division of Nissan North America, Inc.